

# HAND REEL

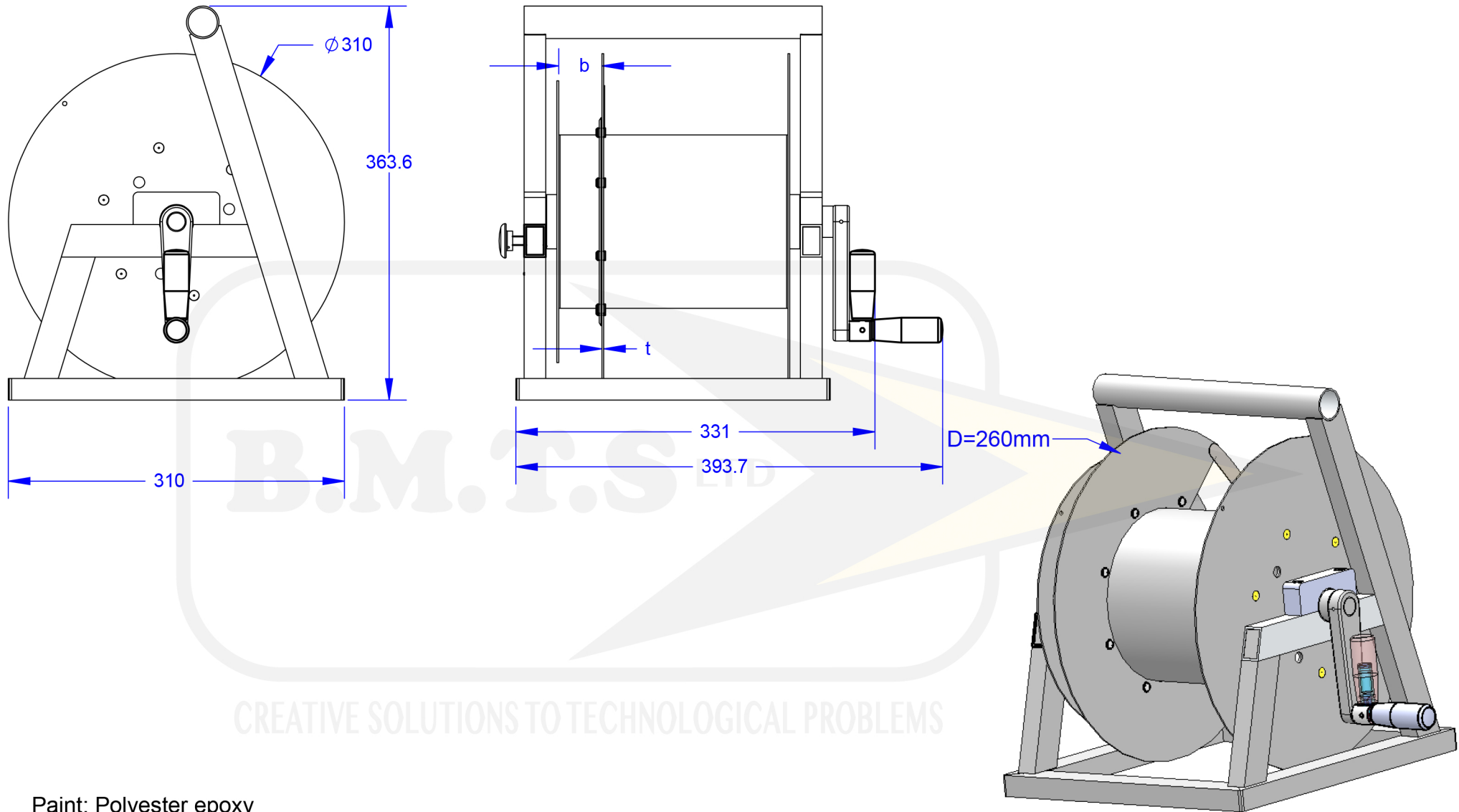

Paint: Polyester epoxy

\* Width of connector department (b) can vary on demand

\*\* Weight includes textile accessories

Product P/N	Diameter D	*b	Flange Thickness t	** Weight	Main Material	Connector Strap (Qty.2)
	[mm]	[mm]	[mm]	[kg]		P/N
666-310-160-40	310	40	1.6	3.2	Aluminium	1257-100-1170

**B.M.T.S LTD**  
**+972 3 - 6827796**  
**fottads@bmtsltd.com**  
**14 HaThiya St.**  
**TEL - AVIV**