

HAND REEL

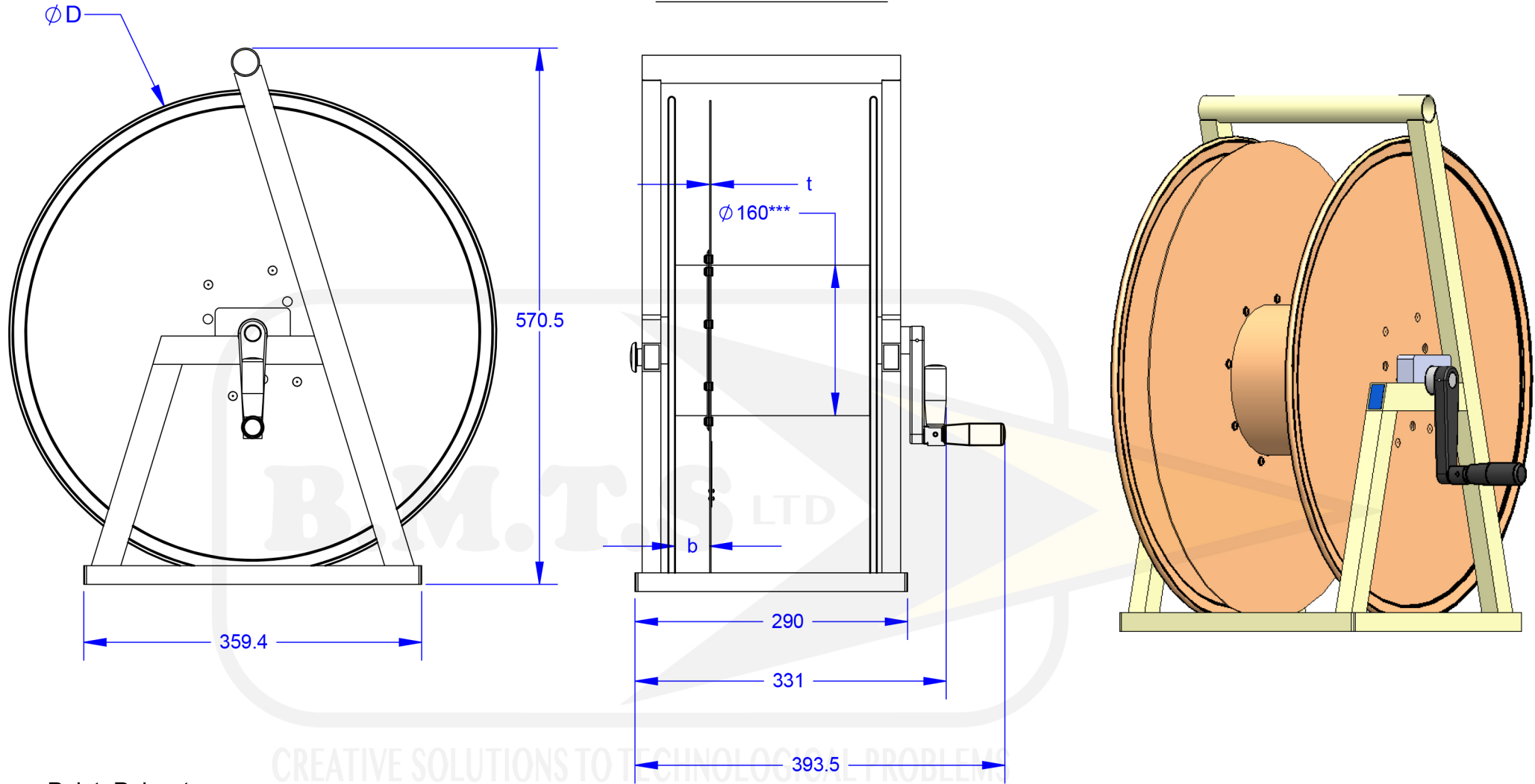

Paint: Polyester epoxy

* Width of connector department (b) can vary on demand

** Weight includes textile accessories

*** Different diameter can be ordered to fit Bending radius of cable

Product P/N	Diameter D	*b	Flange Thickness t	** Weight	Main Material	Connector Strap (Qty.2)
	[mm]	[mm]	[mm]	[kg]		P/N
963-60-510-40	518	40	1.6	6.75	Aluminium	1257-100-1170

B.M.T.S LTD
+972 3 - 6827796
fottads@bmtsltd.com
14 HaThiya St.
TEL - AVIV