

REEL PUSH CART

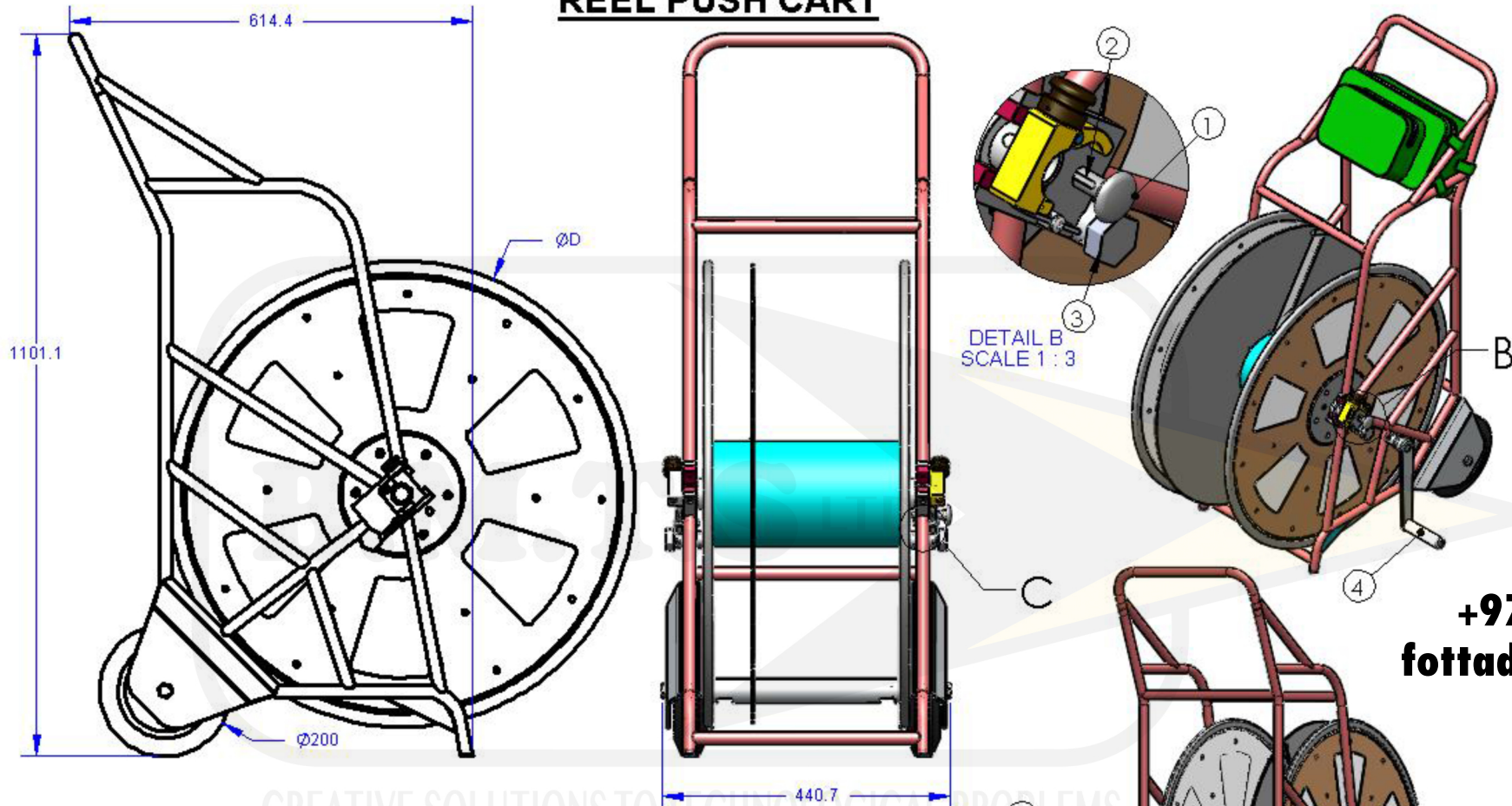

B.M.T.S LTD
+972 3 - 6827796
fottads@bmtsltd.com
14 HaThiya St.
TEL - AVIV

Paint: Polyester epoxy

1	BRAKING KNOB
2	LOCKING PIN
3	FRICTION BRAKE
4	CRANKED HANDLE P/N 611-00-10

* Cable Reel up to $\varnothing 700$ including Brake Plates to be ordered separately.

** Weight includes textile accessories

Product P/N	Diameter D (max)	** Weight	Main Material
	[mm]	[kg]	
963-60-700-WBR-BRK-2	700	8.2	Aluminium

DETAIL C
SCALE 1:2