

# WINDING FRAME WITH FRICTION BRAKE

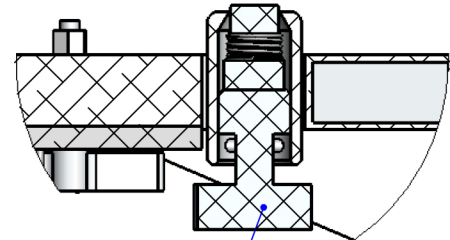

Friction brake  
B-B  
1:2

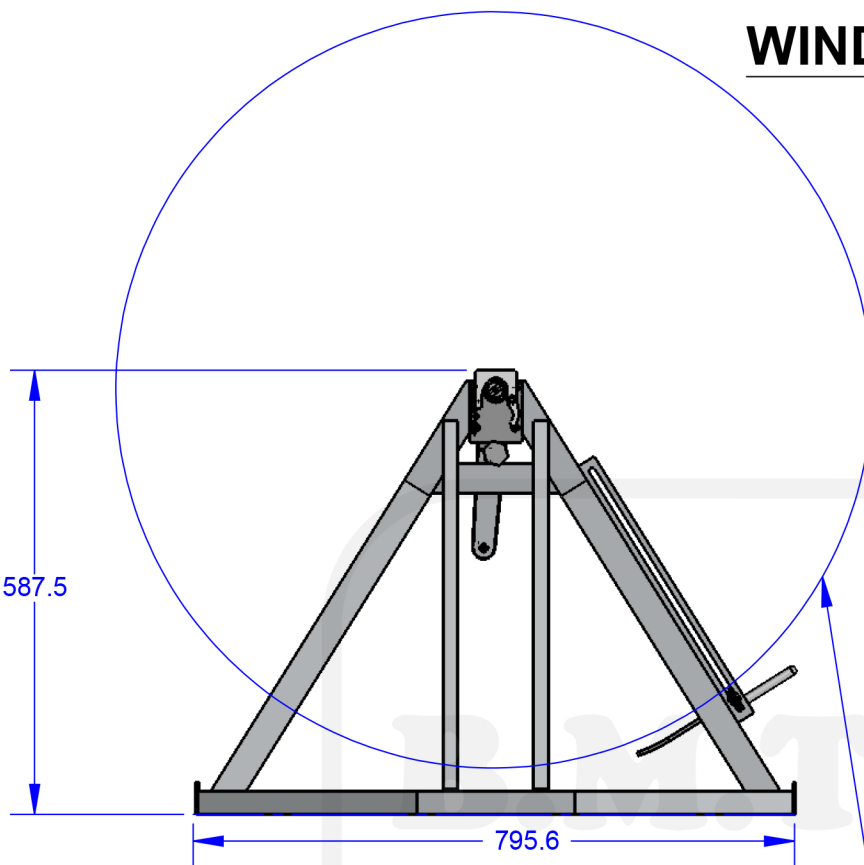
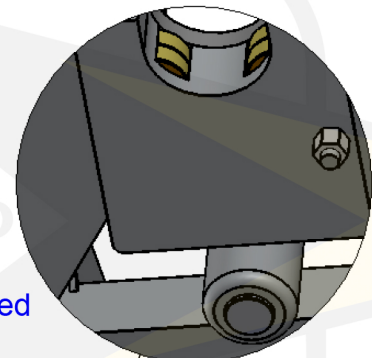
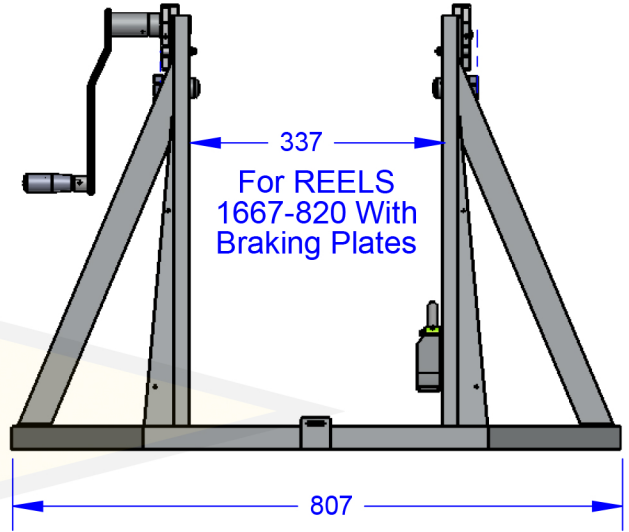

Ø 1000 max  
REEL not included

DETAIL A  
SCALE 1 : 2

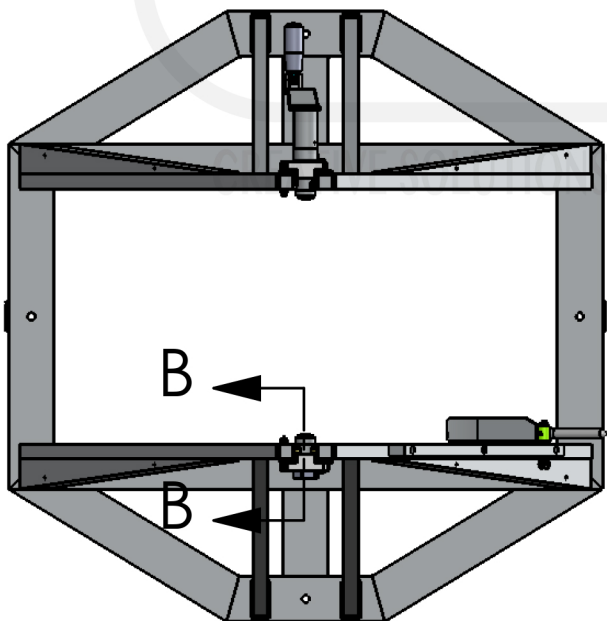

Hand brake

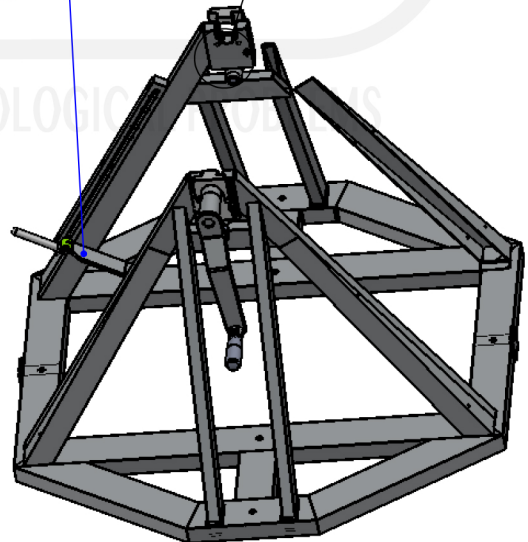

Paint: Polyester epoxy

Winding Frame	P/N 520-90-1000
Foldadle Cranked Handle	P/N 611-30-10
Braking Blanket	P/N 1257-300-750
Main Material	Aluminum
Weight (without Reel)	9.4 kg

**B.M.T.S LTD**  
**+972 3 - 6827796**  
**fottads@bmtsltd.com**  
**14 HaThiya St.**  
**TEL - AVIV**