

HAND REEL

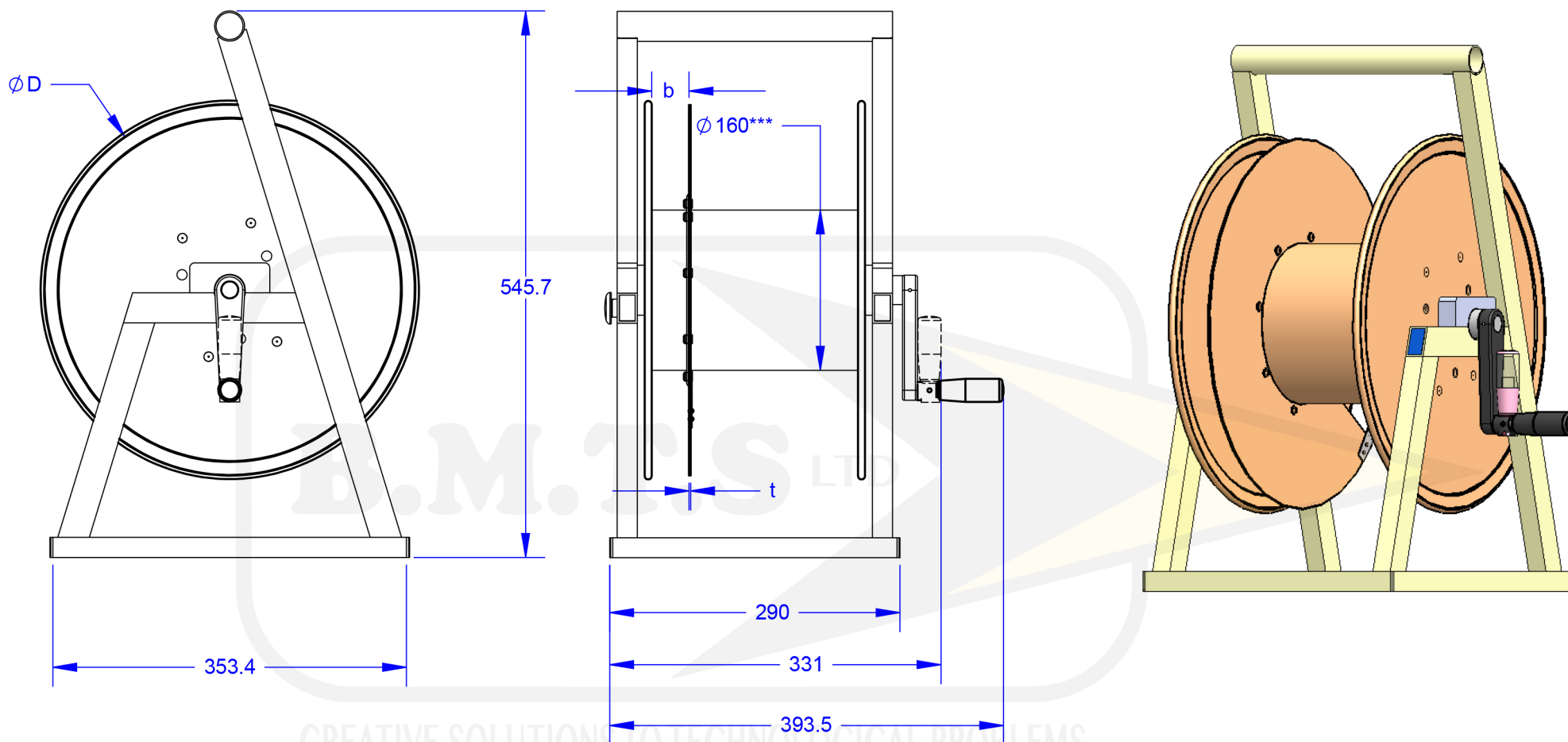

Paint: Polyester epoxy

* Width of connector department (b) can vary on demand

** Weight includes textile accessories

*** Different diameter can be ordered to fit Bending radii of cable

Product P/N	Diameter D	*b	Flange Thickness t	** Weight	Main Material	Connector Strap (Qty.2)
	[mm]	[mm]	[mm]	[kg]		P/N
963-60-310-40	318	40	1.6	4.70	Aluminium	1257-100-1170
963-60-370-40	378	40	1.6	5.20	Aluminium	1257-100-1170
963-60-460-40	468	40	1.6	6.00	Aluminium	1257-100-1170

B.M.T.S LTD
+972 3 - 6827796
fottads@bmtsltd.com
14 HaThiya St.
TEL - AVIV